

## FUSION™ LIGHTED MIRROR

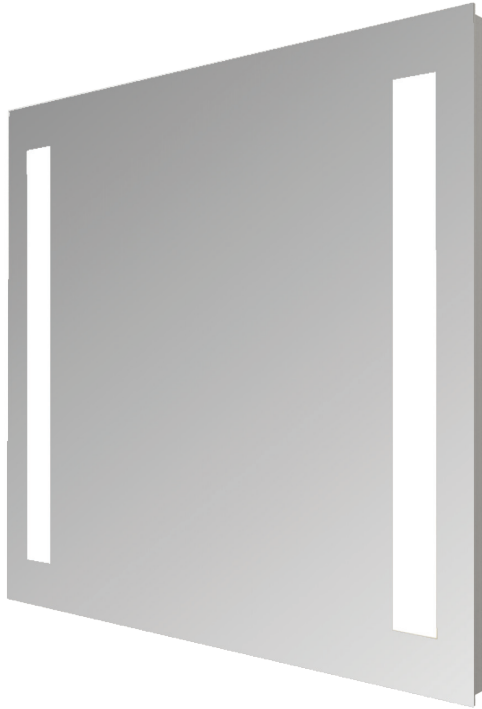

The Fusion™ Lighted Mirror embodies modern innovation, clean lines, and efficient natural lighting.

### FEATURES

- E-Life™-8 Years Extended Lamp Replacement Cycle
- Natural Light Color
- HardCoat™ Anti-Corrosion Mirror Treatment
- Environmentally Sustainable
- Energy Efficient
- Proudly Made in The USA

### LIGHTING

- Low-Mercury T5HO Warm Fluorescent (US Made)
- CRI 85
- CCT (K) 3000
- 50,000 Cycle Ballast

### OPTIONS

- Custom Sizes Available
- Add a TV (See Fusion Lighted Mirror TV)
- Add Keen™ Technology
- Add Vive™ Technology
- Diamond Clear™
- Add Frame (See Reflection Lighted Mirror)
- Dimmable
- Defogger
- Night Light (See Reflection Lighted Mirror)
- Glass Shelf
- LED Digital Clock
- LED Lighting
- Wall Glow
- EnergyLite™

### SAFETY

- Tested to UL/UL-C 1598 Including Section 16.23
- International Certifications
- Safety Backed Mirror

### THERE'S ONLY ONE™ ELECTRIC MIRROR®

Electric Mirror is the global leader in Lighted Mirrors and Mirror TV technology. With unparalleled customer service and amazing innovation, Electric Mirror is the standard of luxury for five-star hotels, upscale commercial projects and designer homes.

**PROPRIETARY AND CONFIDENTIAL:** The information contained in this specification is the sole property of Electric Mirror®. Any reproduction in part or in whole without written permission from Electric Mirror® is prohibited.

© 2014 ELECTRIC MIRROR®

# FUSION™ LIGHTED MIRROR

## SPECIFICATION

- The top of the lighted mirror above the bathroom vanity should be a minimum of 6' 6" above the finished floor.
- Electrical connections made with MC cable brought through the chassis knockout, no electrical box required.
- Electrical power should be controlled by a light switch.
- Fixture should be mounted to wall studs to provide sufficient support. Mounting holes are provided in the chassis.

MODEL NUMBER	DIMENSIONS	POWER REQUIREMENTS	LAMPING
FUS-24.00x28.00	24" W x 28" H x 2" D 610mm x 711mm x 50.8mm	120 - 277 VAC, .40 - .17 Amps, 48W	2 x T5HO, 24W
FUS-28.00x36.00	28" W x 36" H x 2" D 711mm x 914mm x 50.8mm	120 - 277 VAC, .65 - .28 Amps, 78W	2 x T5HO, 39W
FUS-36.00x36.00	36" W x 36" H x 2" D 914mm x 914mm x 50.8mm	120 - 277 VAC, .70 - .28 Amps, 78W	2 x T5HO, 39W
FUS-42.00x40.00	42" W x 40" H x 2" D 1,067mm x 1,016mm x 50.8mm	120 - 277 VAC, .70 - .28 Amps, 78W	2 x T5HO, 39W
FUS-48.00x40.00	48" W x 40" H x 2" D 1,219mm x 1,016mm x 50.8mm	120 - 277 VAC, .70 - .28 Amps, 78W	2 x T5HO, 39W
FUS-60.00x40.00	60" W x 40" H x 2" D 1,524mm x 1,016mm x 50.8mm	120 - 277 VAC, .70 - .28 Amps, 78W	2 x T5HO, 39W

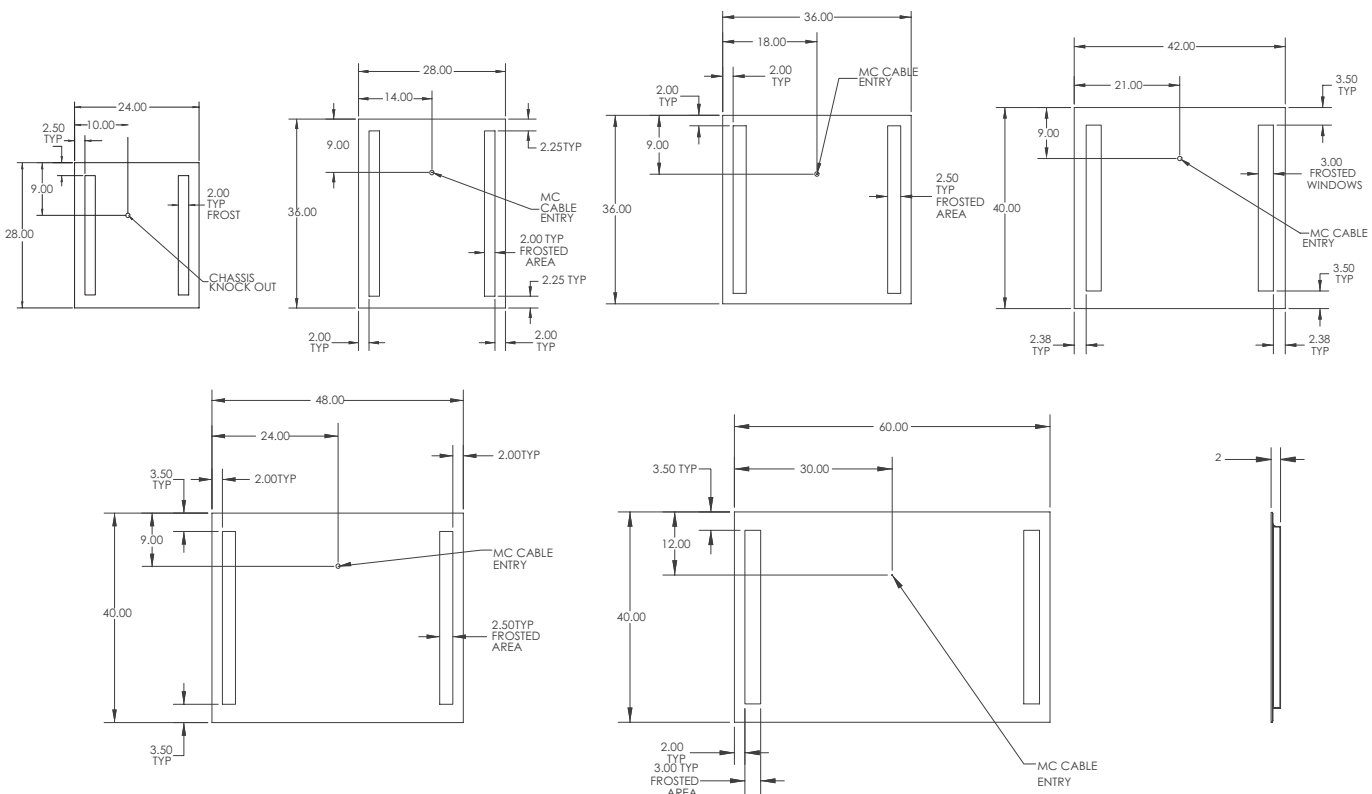

**PROPRIETARY AND CONFIDENTIAL:** The information contained in this specification is the sole property of Electric Mirror®. Any reproduction in part or in whole without written permission from Electric Mirror® is prohibited.

© 2014 ELECTRIC MIRROR®