



PARTS LIST: FS-200-CHV

- | | | |
|-----|------------|---|
| (1) | CHAV-442 | Cross Handle Angle Valve |
| (2) | SH-013 | 1" Chrome Plated Brass Aerating Shower Head, 45° Nipple |
| (3) | FS-45-ELL | Stainless Steel 45° Nipple (TBE) Threaded both ends |
| (4) | AB-238-CS | 3 Carbon Steel Drive Anchor Bolts—3/8" X 2-3/8" |
| (5) | BCB-6 | 6" Stainless Steel Base Cylinder with Brackets |
| (6) | PTC-2734 | 3/8"X3/8" Stem Elbow Push to Connect |
| (7) | PTC-1264 | 3/8"X 1/2" Push to Connect Adapter Fitting |
| (8) | 3/8 TUBING | 3/8" OD Polyethalene Tubing |
| (9) | BHS-516 | 5/16" Button Head Socket Head Screws (3) |



ADA COMPLIANT METERED PUSH VALVE TIMING

NOTE: If leak occurs at cap gasket, remove gasket and inspect it for damage and replace if necessary. If the gasket is in good condition, inspect the body surface for scratches or nicks and clean up the surface by reaming if necessary.

TIMING ADJUSTMENT:

These instructions are for the user to adjust the faucet to provide a flow rate to meet the American Disability Act (ADA) regulations which require 10 seconds running time for the water flow. For ADA compliance follow these procedures:

NOTE: Timing must be checked with the handle in place.

- A) Purge the valve of air by pushing it completely open 4-8 times rapidly and then check the timing cycle.
- B) Remove the handle with a 3/32" hex wrench.
- C) Time is changed by rotating plastic serrated adjustment nut with a pair of pliers. Raising nut (counter clockwise) shortens time, lowering nut (clockwise) lengthens time.
- D) After each adjustment, replace handle and check cycle time.

- FREE STANDING UNIT
- 304 STAINLESS STEEL BASE
- CHROME PLATED BRASS VALVES
- CARBON STEEL DRIVE ANCHOR BOLTS
- 304 STAINLESS STEEL BASE AND BASE COVER
- STAINLESS STEEL & CHROME PLATED BRASS DRINKING FOUNTAIN BUBBLER
- CHROME PLATED BRASS HOSE BIBB
- STAINLESS STEEL & CHROME PLATED BRASS HAND SPRAY

- ASME A112.18.1 COMPLIANT
- CSA B125 COMPLIANT
- CSA B 64.2 COMPLIANT
- ANSI/NSF Std. 61-1999a

Drinking Fountain Bubbler Height: 32"-36"
 Hose Bibb Height: 16"
 Foot Shower Accessory Height: 24"

NOTE: Flush supply lines before installing accessories to remove chips and dirt which can become lodged in the seat washer and cause the faucet to malfunction.

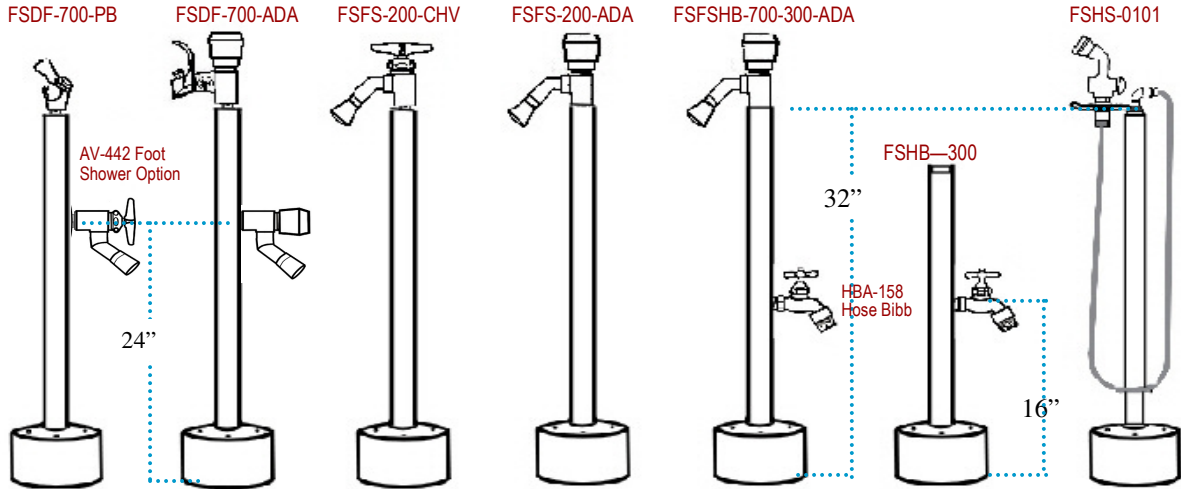

Dimensions and placement of accessories can vary depending on the style and design. All products meet all Standard Plumbing

AV-442-CHV ANGLE VALVE

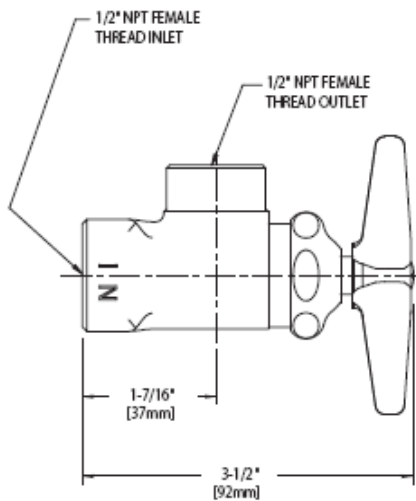

HS-0101-60 HAND SPRAY & HOSE

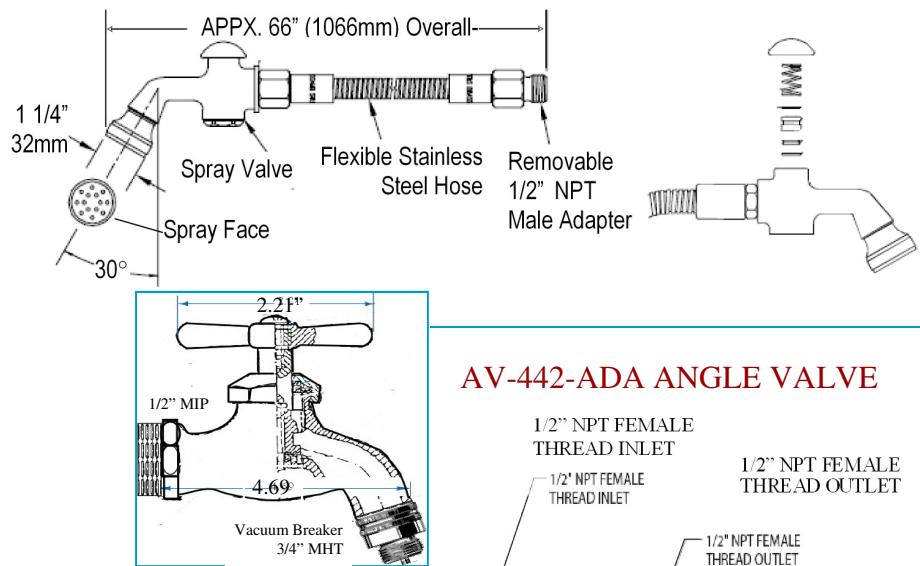

AV-442-ADA ANGLE VALVE

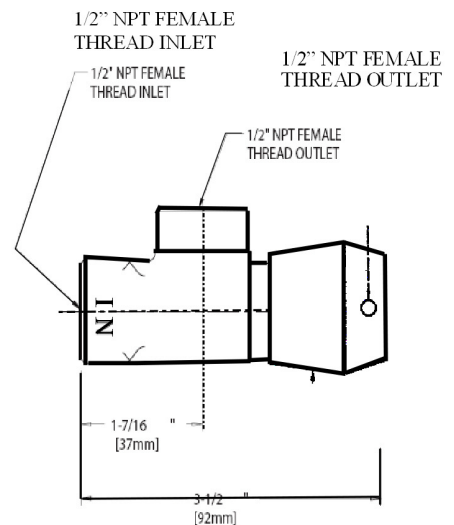

DF-748-665 BUBBLER

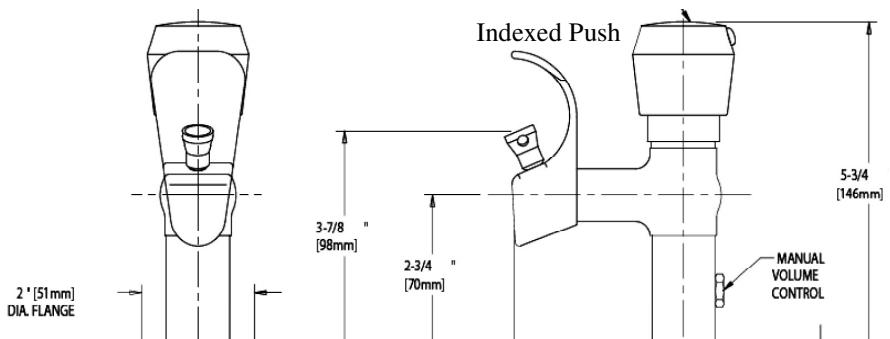

WINTERIZING: It is recommended that a shut-off valve be installed in the water line going to the shower connection where freezing temperatures can occur. Accessories can be removed and other parts partially disassembled for complete protection against freeze damage.

FREEZE DAMAGE IS NOT COVERED BY THE WARRANTY.

FREE STANDING COLD WATER SHOWER UNIT INSTALLATION

Items needed: 9/16" wrench and crescent wrench, hammer, roto hammer, 3/8" drill bit, Teflon tape



TOP VIEW

Flush lines before installing valves and shower head. Debris in water line can cause valves to malfunction.

1. Run a 1/2" water supply line at the desired location of the shower unit.
2. Attach 1/2" water supply line to 1/2" x 3/8" straight adapter.
3. Using Lower Bracket pre-drilled holes of the Base Cylinder as a guide, mark the placement of the drill holes at desired location of installation. Drill 3, 3/8" holes, 3" deep.
4. Attach Elbows and Adapters to Hose. Attach one end to water supply line coming out of the ground.

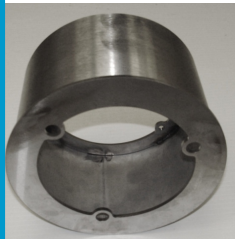

BOTTOM VIEW

5. Position Base Cylinder to line up with pre-drilled holes in flooring surface. Insert Anchor Bolts in each hole. When bolts are in position hit the pin of the bolt with a hammer, locking it into place. Tighten nuts.

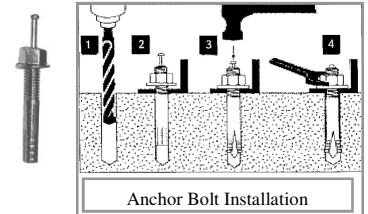

6. Lay Shower Base and Cover Plate on Base Cylinder and attach other end of hose to opening on underside.



7. Curl hose inside Base Cylinder and place Base Plate on top, lining up with holes.

8. Stand shower base in upright position and attach Base Plate to Base Cylinder using button head cap screws.

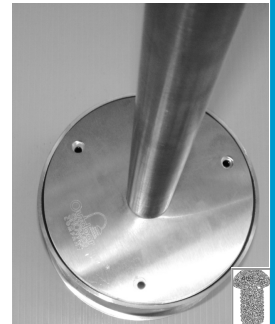

Teflon Tape is not needed when attaching Shower Heads or other accessories with washers.

PS-900, PS-1000, PSDF-1500, BS-2000

- Attach straight valve to lower portion of shower unit, and attach riser to valve using Teflon Tape.
- Attach accessories to base using Teflon Tape.

FSFS, FSDF, FSHS, FSHB

- Attach angle valve to top of shower base using Teflon Tape.
- Attach accessories to base using Teflon Tape.

PS-3200, PS-3300, PS-3400

- Attach brackets, valves, hose bibb, and riser to shower unit body using Teflon Tape as shown in Specification sheet included shower unit.

WINTERIZATION

It is recommended that a shut off valve be installed in the supply line going to the shower unit for winterization. To prevent freeze damage remove and store shower unit leaving Base Cylinder anchored to flooring surface. If the shower unit is left outdoors cut off water supply, completely drain or blow out all moisture, and remove all accessories and valves.

FREEZE DAMAGE IS NOT COVERED BY THE WARRANTY.

WARRANTY / RETURN POLICY MAINTENANCE



All items manufactured by Outdoor Shower Company, LLC. are manufactured in Dallas, Georgia, and we guarantee 100% customer satisfaction. Only the finest stainless steel materials are used. Each piece is individually crafted and is electro-polished, which smoothes, polishes, and deburrs the product surface, making it easier to clean and resistant to contamination.

Stainless steel materials come with a ten (10) year limited warranty against defect and workmanship. All accessories not manufactured by Outdoor Shower Company, LLC are covered by warranty for a period of two (2) year from the receipt by the original purchaser. This warranty will become void if merchandise is damaged, improperly maintained or installed, or modified without the authorization from our licensed distributor.

The warranties include replacement or repair of defective parts and an unconditional guarantee against manufacturing defects. The company will replace or repair at its option any equipment manufactured or supplied as part of our merchandise found to be defective if the conditions are met. Any shipping fees associated with the return or replacement of merchandise covered by this warranty will be incurred by Outdoor Shower Company, LLC **We reserve the right to determine if damage to a unit or any parts is the direct cause of not complying with manufacturer's guidelines. Special Order non-stock items are NOT returnable.**

WARNING: FREEZE DAMAGE is NOT covered by the warranty.

It is very important to winterize outdoor showers. Just like water faucets and hose bibbs, they are susceptible to freeze damage. The unit(s) must be drained in freezing conditions. In extremely cold temperatures it is advisable to remove faucets and hose bibbs and store them during winter months. Vented plugs are available through The Pool Shower, Inc.

Although care was taken in the design and manufacture of your new pool shower to ensure it's safe operation, we accept no responsibility for the improper use or installation of equipment, as it is no longer in our control. Buyers have the right of inspection, approval, and acceptance within thirty days of arrival.

We will not be responsible for transportation or labor for items returned for repair or replacement of parts where the merchandise was not properly installed or maintained. An authorized distributor must request a Return Authorization Form from Outdoor Shower Company, LLC, and submit it before the return can be approved. A 20% re-stock fee and the cost of shipping will be withheld on returns.

Our Customer Service Department is available for ordering replacement parts or if it should become necessary for you to return your Pool Shower unit. We can also repair or replace damaged parts for a minimal fee. Call **678-363-3939** or **1-866-SHOWER1** for return authorization and instructions, or E-mail us at info@outdoorshowerco.com.

Additional information is available at www.outdoorshowerco.com.

CAUTION: Where outdoor temperatures reach more than 90 degrees use caution to prevent burns to skin from scalding water. When a shower unit is connected to an exposed water hose, it is recommended that a light colored hose be used in order to reduce solar gain and keep water temperature inside the hose near the ambient temperature. Water is stored in the body of the shower unit when not in use, and although the patented satin finish on our stainless steel components has minimal solar gain, in warm climates water temperatures inside the hose or shower unit can reach more than 110° which can result in minor burns to delicate skin tissue.

HOT & COLD SHOWER UNITS: Some states require Pressure Balancing Valves for hot & cold valves. These are available through any plumbing supply company and can be added to the water supply lines feeding into the shower valve. When hot water is used for bathing it is always recommended that the temperature on the water heater be set at 110° or less in order to prevent the risks of minor burns from scalding water.

does not accept responsibility for bodily injury caused from improper use of its equipment or failure to use caution when operating the shower unit(s). It is recommended that the shower unit(s) be turned on for 30 seconds before contact with water spray in order to avoid accidental scalding and ensure safe use of this product.

Stainless steel does not "rust" as you think of regular steel rusting with a red oxide on the surface that flakes off. If you see red rust it is probably because the product was contaminated, steel or iron scratched the surface, and particles became embedded in the surface. These particles are much less corrosion resistant than the stainless steel and rust, making it appear that the stainless steel is rusting. Stainless steel should never be cleaned with steel wool or an abrasive cleaner. Brillo and S.O.S. pads are made of steel wire. Iron particles from these pads will contaminate the surface. NEVER use an iron-based product on stainless steel. Damp steel or cast iron can be left behind causing the stainless steel to stain (rust). In most cases, light staining can be removed with a fine abrasive cleaner, scouring powder, or non-metallic abrasive scouring pad such as a Scotch Brite® pad. Apply the cleaning product in the same direction as the polish to minimize damage. Stainless Steel cleaner is suggested and can be purchased at most home improvement stores. WD-40 is also an excellent cleaner and polisher of stainless steel. If there are obvious polishing lines rub in the same direction as the grain of the steel to minimize surface finish damage.